

LARGHEZZA PROFONDITÀ / LENGHT WIDTH

Interne / Inside

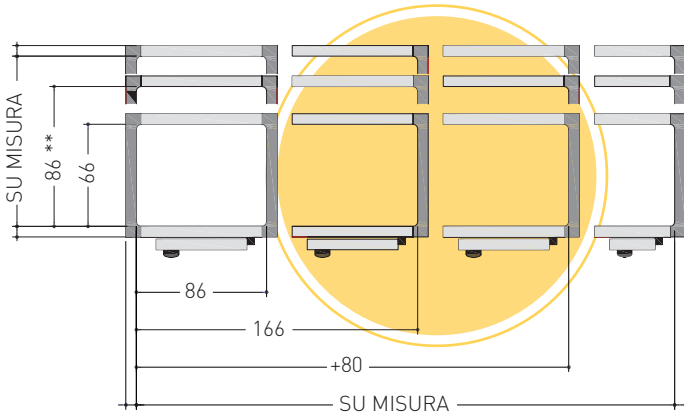

** per pasticceria ogni guida 2 teglie 600x400

ISOLAMENTO / INSULATION

- Poliuretano espanso ad alta densità 40-42 kg/m³, autoestinguento secondo la norma ISO 3582, privo di CFC.
High density polyurethane foam 40-42 kg/mc, fire retarding according ISO 3582, CFC free.
- Coefficiente di conducibilità termica 0,021 W/m² °K.
Thermal conductivity coefficient Lambda 0,021 w/m² °k.
- Coefficiente di trasmissione K per spessore 70 mm 0,30 W/m² °K, per spessore 100 mm 0,21 W/m² °K.
Transfer coefficient k thicknesses 70 mm 0,30 w/m² °k thicknesses 100 mm 0,21 w/m² °k.
- Resistenza alla compressione 1,5-2 Kg/cm².
Compression resistance 1.5 - 2 kg/cm².

RIVESTIMENTO PANNELLI / PANELS FINISHING

- Lamiera zincoplastificata spessore 6/10 mm + PVC bianco atossico spessore 120 micron, certificata per uso alimentare.
Galvanized sheet steel with plastic coating in rigid white PVC 120 micron thick non toxic.
- Acciaio inox 18/10 AISI304 satinato opaco.
AISI304 18/10 stainless steel scotch bright / dull.
- Lamiera zincoplastificata, colore a richiesta.
Galvanized sheet steel with plastic coating in different colours.



SPESSORI / TICKNESSES

- Standard 70-100
Standard 70-100
- Su misura 70-100-130-a richiesta
Custom 70-100-130-on demand

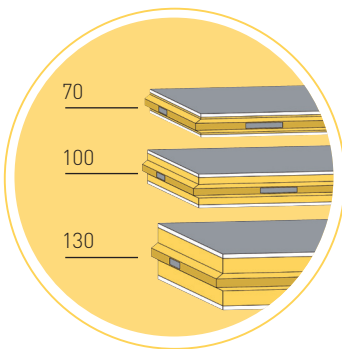

ALTEZZE / HEIGHTS

Esterna = interna + 2S

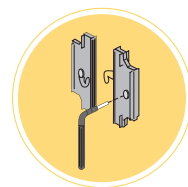
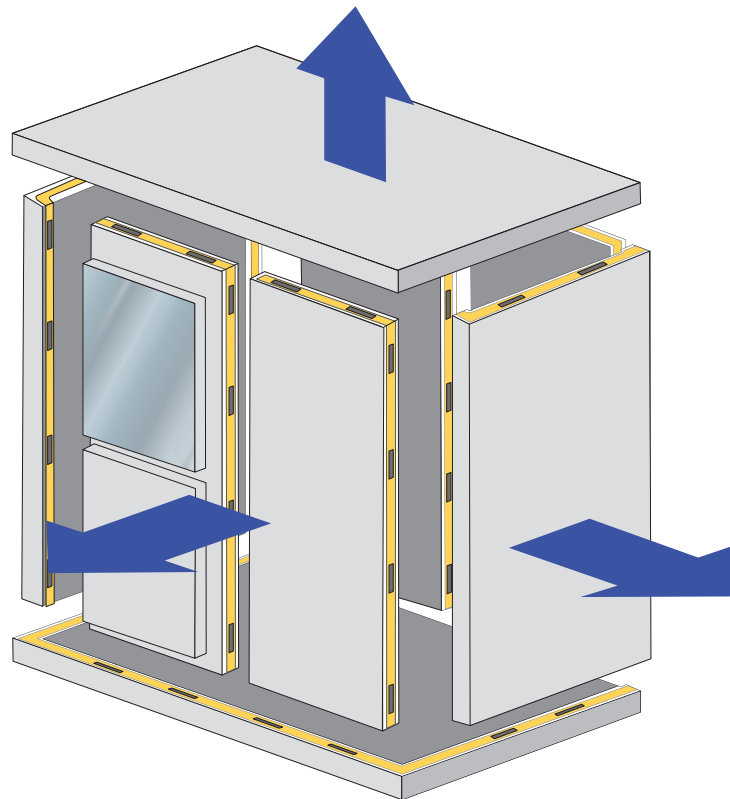
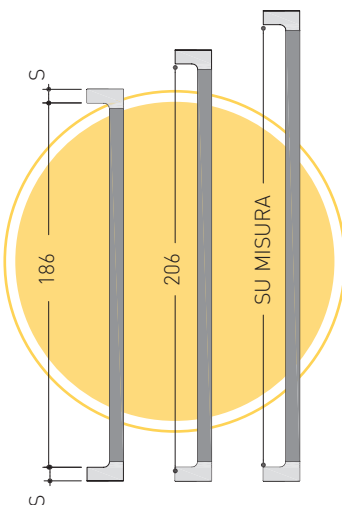

UNIONE CON GANCI
ECCENTRICI A
DOPPIO EFFETTO /
CONNECTION WITH
DUAL EFFECT CAM
LOCKS

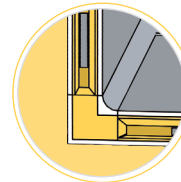

ANGOLI ARROTONDATI /
INSIDE ROUNDED
CORNERS

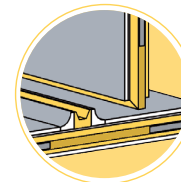

DIVISORIO AGGANCIATO /
CAM LOCKS DIVIDING
COLLECTION

ACCESSORI / OPTIONAL

